



**TRUSTED TECHNICAL INFORMATION FOR  
THE AUTOMOTIVE AFTERMARKET**



**COMPREHENSIVE . INNOVATIVE . BUSINESS FOCUSED**

# About us

## What we do

Autodata is Europe's leading supplier of technical information to the automotive aftermarket; supporting the service, maintenance, diagnostics and repair of vehicles.

With over 40 years of experience, our trusted workshop applications are widely acknowledged as the most comprehensive and innovative solutions on the market.

# Key statistics



**600,000**

technical  
procedures &  
instructions



**24/7**

round the clock  
availability

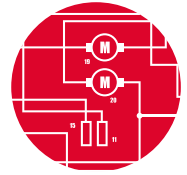

**90,000**

wiring diagrams  
and illustrations



**34,000**

vehicles



**2 million**

lines of  
technical data  
and specifications



**142**

manufacturers

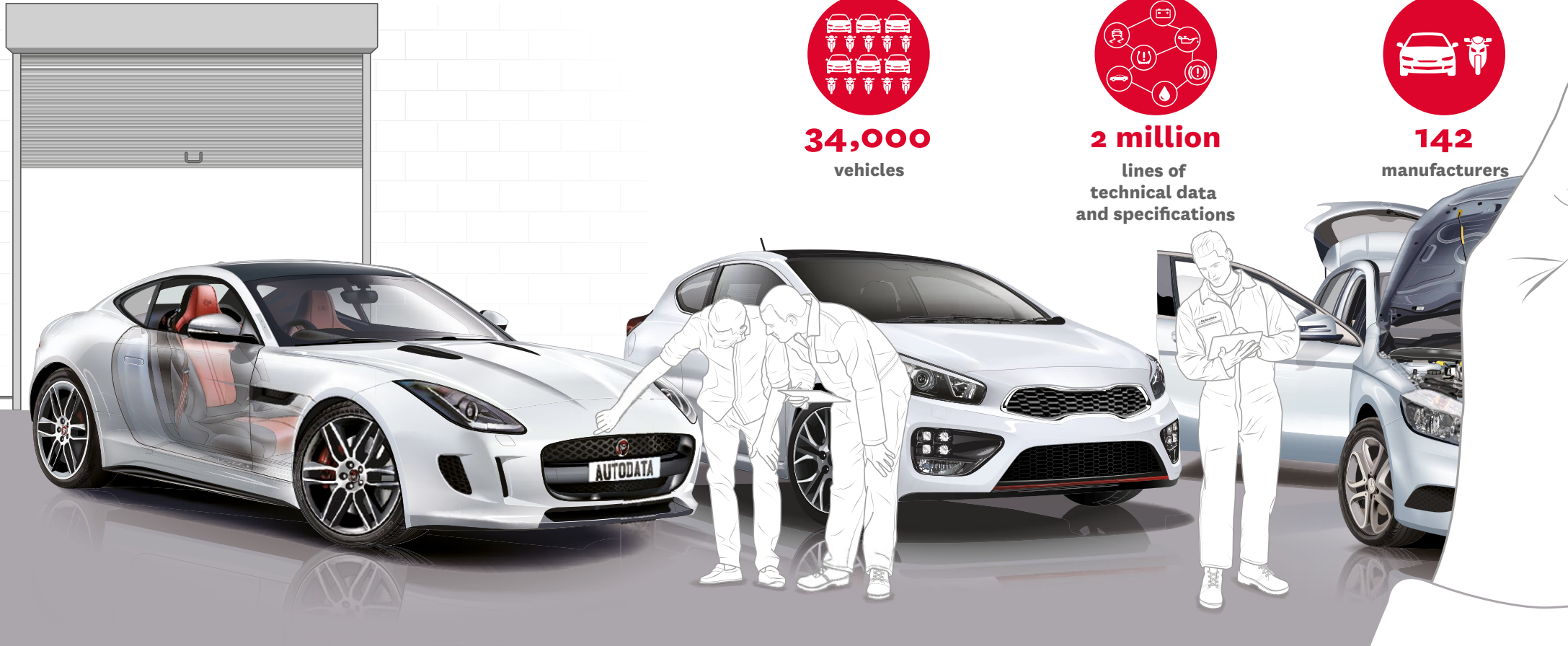

# Assist me

Assist me is Autodata's diagnostic assistant, developed to further optimise efficiency in the workshop.

Step-by-step guides help you quickly identify probable causes and possible known fixes for your customer's car, saving you valuable time and money.

## Step 1:

Input the fault code into Autodata's Diagnostic Trouble Codes module.

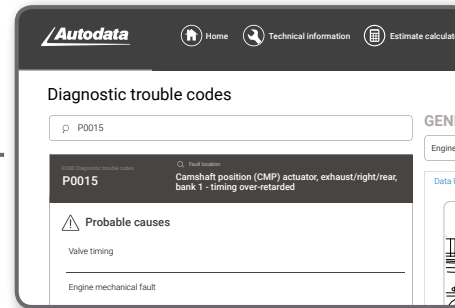

## Step 2:

The DTC module will show a list of probable causes and known fixes.

This may be all you need to identify and fix the fault in your customer's car.

## Step 4:

Test the component using the Component Checks and Control Module Pin Data tabs.

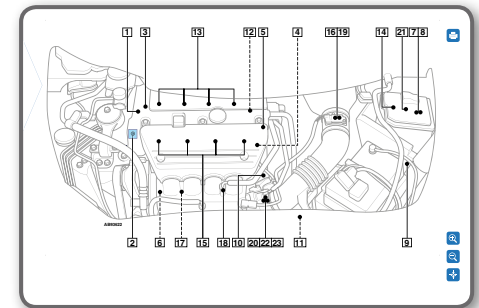
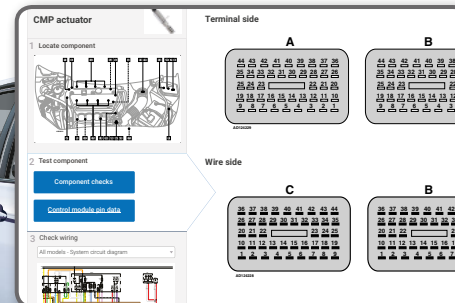

## Step 3:

If not, click through to the new Assist me feature and locate the faulty component.

## Step 5:

Use one of Autodata's 17,500 full colour and interactive wiring diagrams to ensure all wiring is present and correct.

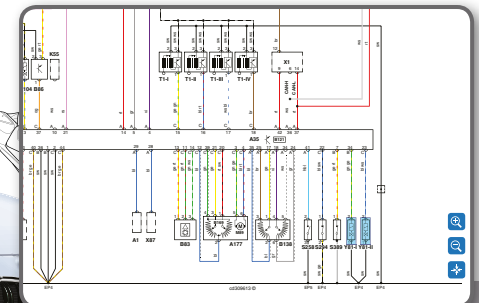

# Key features & benefits

Accessing accurate technical information quickly and easily is vital for any workshop to operate a respected and profitable business.

Autodata has a constant development programme to provide you with a purpose-built online tool that is accurate, fast and easy to use.

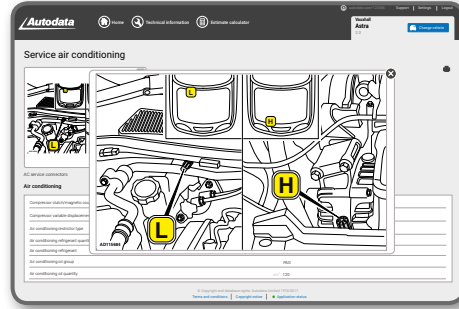
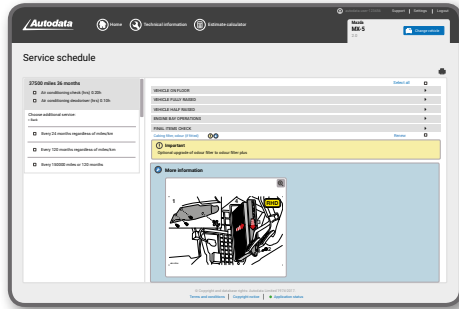

## Everything you need – embedded directly into service schedules

We provide official manufacturers' service schedules including all operations and related technical data with associated illustrations, all embedded directly into the page to save you time.

## Trusted Comprehensive Technical Data

Autodata's technical information is directly sourced from over 140 manufacturers covering more than 34,000 models worldwide.

## Interactive Coloured Wiring Diagrams

Over 17,500 full-colour wiring diagrams that allow you to quickly search for components, zoom in and out, select relevant sections and click through for further details and related data.

## Multi-platform Access

Are you a mobile mechanic? Or maybe you need to remind yourself of something while you're under the car.

We understand modern workshops have an array of different technological requirements so all our platforms are automatically accessible on PC, Mac, tablet and smartphone with no downloads or installs necessary.

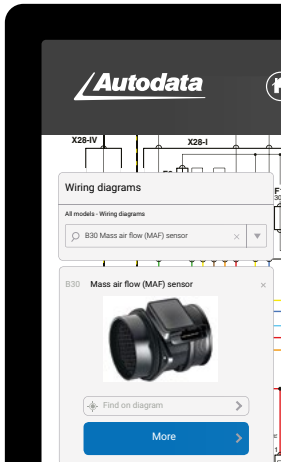
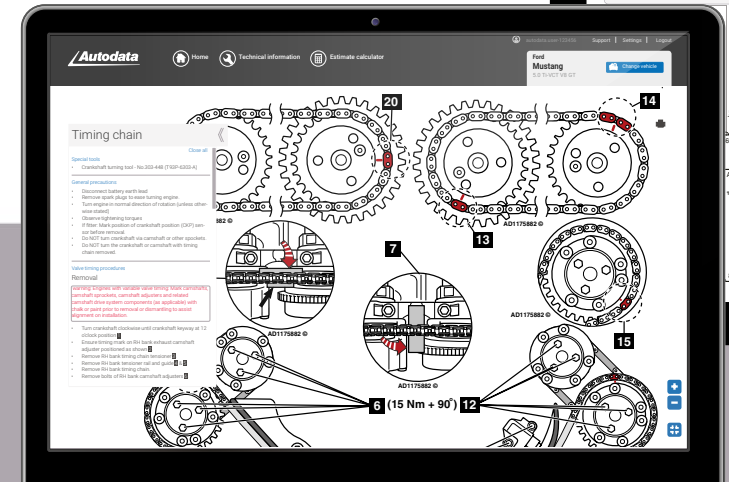

## Easily Swap Between Jobs

Waiting for that one part to arrive? Start working on another vehicle and then use our popular 'recent activity' tab to quickly revisit the exact page you were looking at when you're ready.

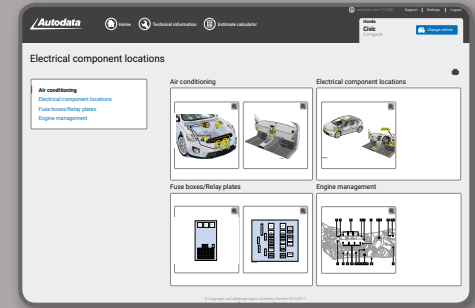
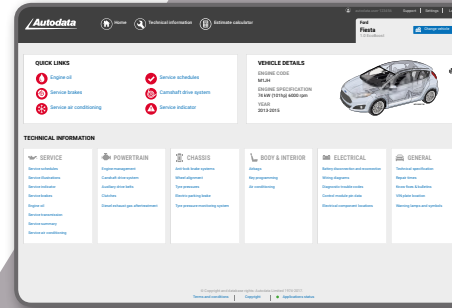

## Quick Links

The Quick Links section has been developed to bring you instant access to the six most common modules in Autodata.

Easily access service modules, engine oil information and the camshaft drive system of your chosen vehicle.

## Component Locations

Our interactive Component Locations page allows you to quickly search for components, see images and access dedicated component information pages, quickly and without fuss, saving you valuable time.

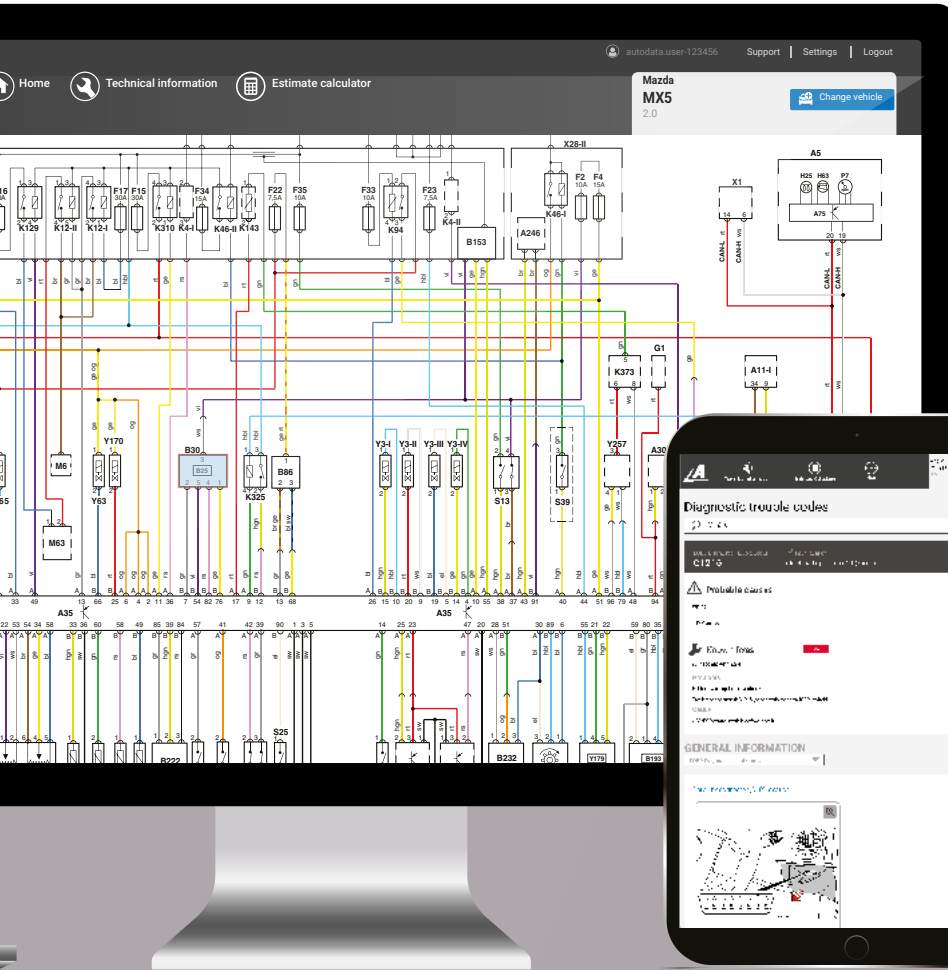

# Subscriptions



## Diagnostic & Repair

In-depth and detailed information you need to carry out more complex diagnostics and repair procedures.

## Service & Maintenance

All the information you need to carry out day-to-day servicing and basic maintenance procedures.

	Diagnostic & Repair	Service & Maintenance
<b>Service guides</b> Official manufacturers' schedules Service illustrations Service indicator Service air conditioning Engine oil Service transmission Service brakes	✓	✓
<b>Maintenance procedures</b> Drive belts/chains replacement Electric parking brake release TPMS Key programming Battery disconnection & reconnection	✓	✓
<b>Technical specifications</b> Repair times Tyres & wheel alignment Fluids & lubricants Tightening torques General component locations Fuse boxes & relays	✓	✓
<b>Diagnostics &amp; troubleshooting</b> Diagnostic trouble codes Assist me Wiring diagrams Control module pin data Electrical component locations Component testing Known fixes & bulletins	✓	
<b>Vehicle systems &amp; repair information</b> Engine management Clutches Diesel exhaust gas after treatment ABS/ESP Airbags Air conditioning	✓	

# What you need to do

It's quick and easy to set up your Autodata subscription. You can be set up and logged on in under five minutes.

Each workshop location subscribes to a single license that can provide access to 1, 2 or 5 users at the same time, all delivered as a 12-month subscription.

- There are no installs or downloads necessary - you just need an internet connection.
- Autodata automatically updates every week with zero downtime, ensuring you have the latest up-to-date technical information whenever you need it.
- Your Autodata account is password-protected, making it extremely secure.

**Visit [www.autodata-group.com](http://www.autodata-group.com) to get started.**

“Autodata is vital for our business, without it we would be guessing so many aspects of the day-to-day details of our work which would cost time and cause unnecessary stress”

Elite Garage Services, Newbury

“The Autodata system is perfect for our business, it's straightforward and convenient”

Llanishen MoT & Service Centre, Cardiff



# Autodata for Motorcycles

Autodata for Motorcycles covers motorcycles, scooters, quad bikes and off-road bikes from 1980 through to today. This includes access to over 8,000 models from 65 manufacturers worldwide and features over 4,000 repair times.

Firmly established as the workshop's bible for routine motorbike servicing and repairs, Autodata for Motorcycles provides quick and easy access to the technical information your workshop needs - all presented in the same trusted, clear and easy-to-use format.

Autodata for Motorcycles is fully online and can be easily added to your existing Autodata subscription or purchased as a standalone.





A Solera Company

[www.autodata-group.com](http://www.autodata-group.com)

Tel: +44 (0)1628 688116

Email: [sales@autodata-group.com](mailto:sales@autodata-group.com)

Interested in integrating Autodata?

Visit

[developer.autodata-group.com](http://developer.autodata-group.com)